

Paver / Road Finishing Chains

A Attachment

Drawing no. 181

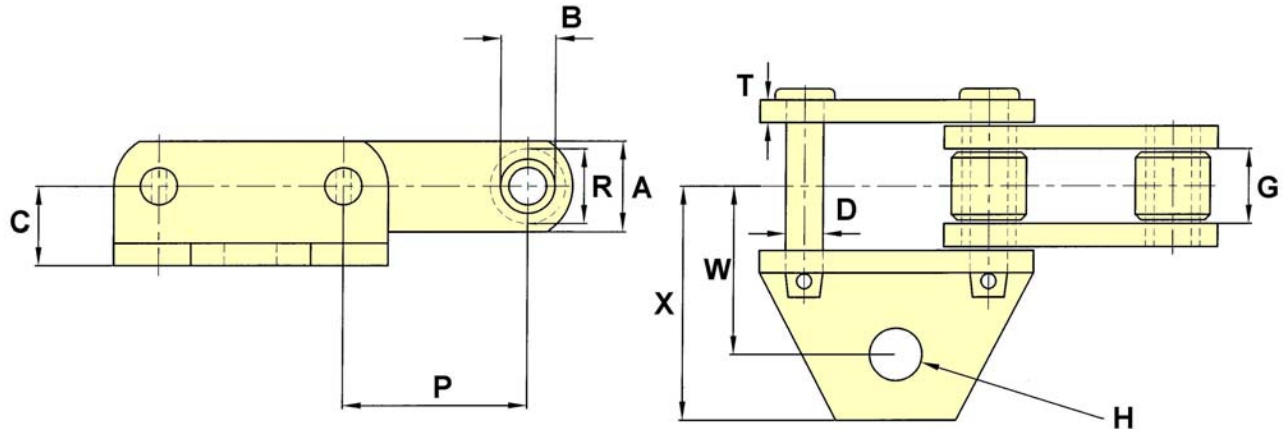

CHAIN NO.	PITCH P	ALLOW. LOAD	U.T.S.	PIN DIA. D	ROLLER DIA. R	SIDEBAR DEPTH A	MAX. GEARING G	BUSH DIA. B	C	BOLT DIA. H	T	W	X
B5045	3.075	4,375	60,000	0.62	1.25	1.50	1.25	0.91	1.31	0.88	0.38	2.75	3.84

A 1 ½ Attachment

Drawing no. 141

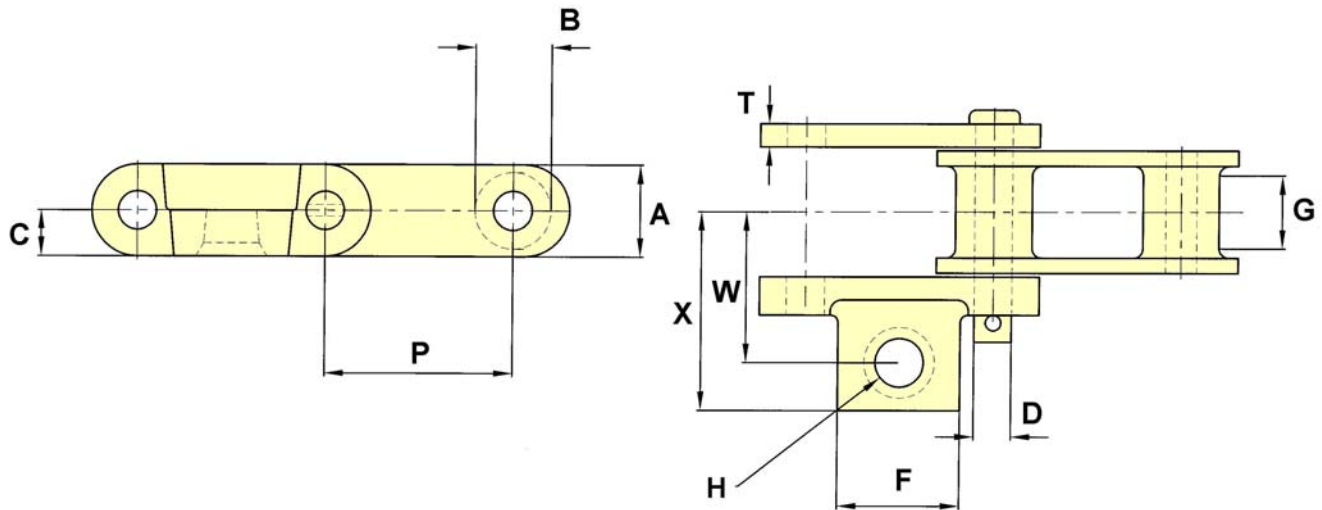

CHAIN NO.	PITCH P	ALLOW. LOAD	U.T.S.	PIN DIA. D	SIDEBAR DEPTH A	MAX. GEARING G	BARREL DIA. B	C	F	BOLT DIA. H	T	W	X
C131	3.075	3,220	27,500	0.62	1.50	1.13	1.25	0.75	2.00	0.75	0.38	2.44	3.22

NORMALLY SUPPLIED WITH ROUND BARREL DESIGN

Paver / Road Finishing Chains

G19 Attachment

Drawing no. 174

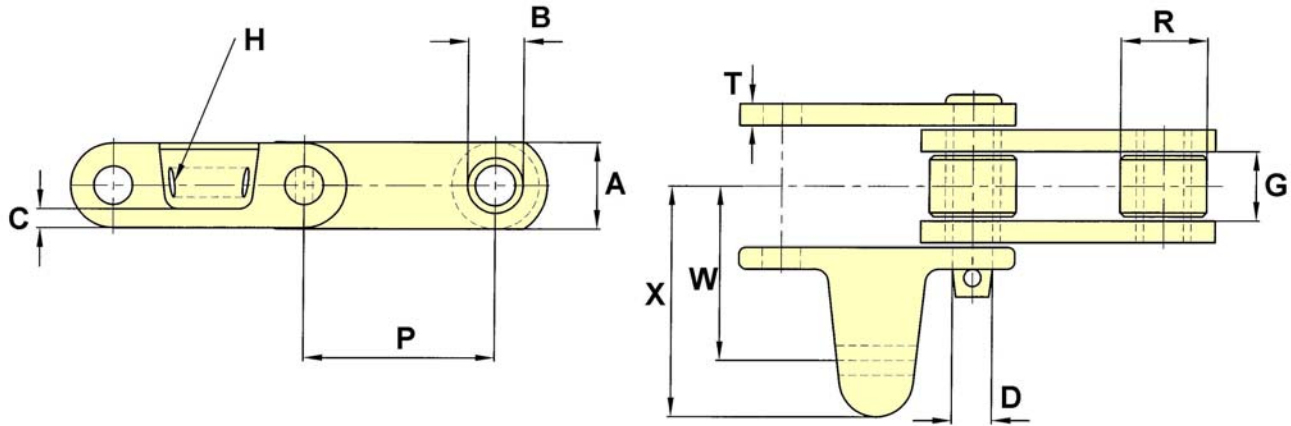

CHAIN NO.	PITCH P	ALLOW. LOAD	U.T.S.	PIN DIA. D	ROLLER DIA. R	SIDEBAR DEPTH A	MAX. GEARING G	BUSH DIA. B	C	HOLE DIA. H	T	W	X
1594	2.75	3,150	30,000	0.56	1.25	1.25	1	0.8	0.25	0.42	0.31	2.47	3.28

H = HOLE DIAMETER - SUITABLE FOR ROLL PIN CONNECTION

Paver / Road Finishing Chains

G19 Attachment with Slotted Centre

Drawing no. 176

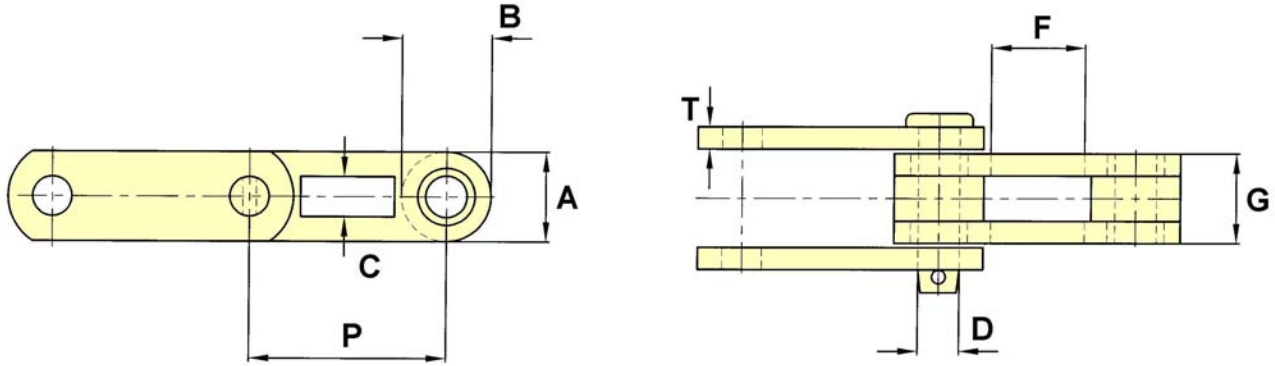

CHAIN NO.	PITCH P	ALLOW. LOAD	U.T.S.	PIN DIA. D	SIDEBAR DEPTH A	MAX. GEARING G	BUSH DIA. B	C	F	T
1598	2,750	2,450	31,500	0.56	1.25	1.25	1.25	0.56	1.31	0.31

Drawing no. 182

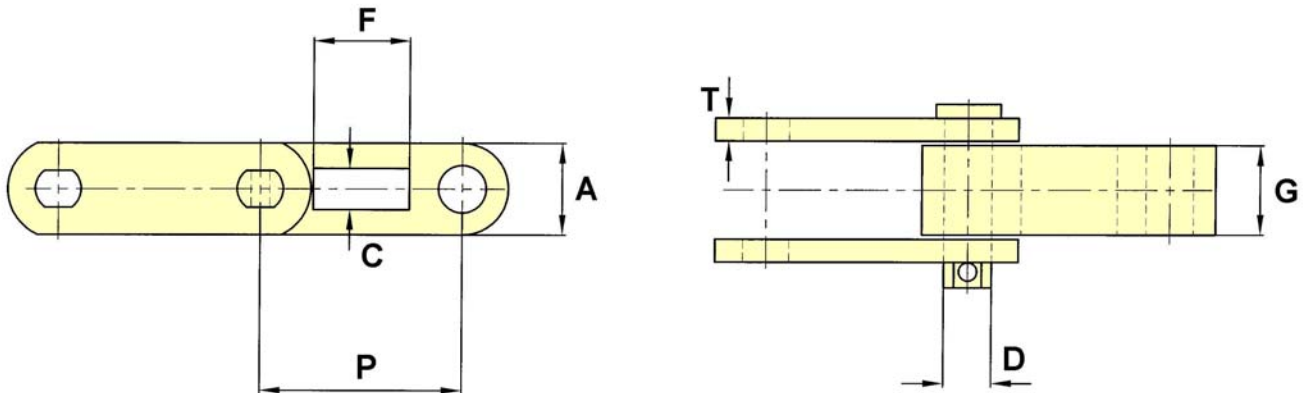

CHAIN NO.	PITCH P	ALLOW. LOAD	U.T.S.	PIN DIA. D	SIDEBAR DEPTH A	MAX. GEARING G	C	F	T
C275	2,750	1,900	20,000	0.62	1.25	1.22	0.56	1.31	0.31

Paver / Road Finishing Chains

Forged Lug

Drawing no. 178

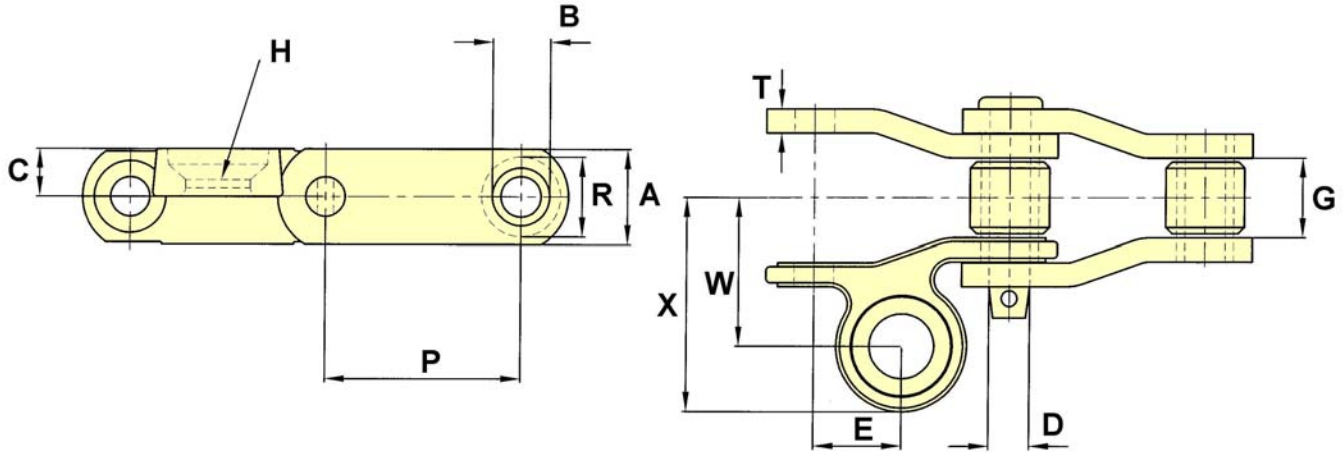

CHAIN NO.	PITCH P	ALLOW. LOAD	U.T.S.	PIN DIA. D	ROLLER DIA. R	SIDEBAR DEPTH A	MAX. GEARING G	BUSH DIA. B			NORMAL RIVET DIA. H			
B5043	3.075	4,375	60,000	0.62	1.25	1.50	1.25	0.91	0.75	1.38	0.75	0.38	2.33	3.36

Paver / Road Finishing Chains

Welded Lug

Drawing no. 177

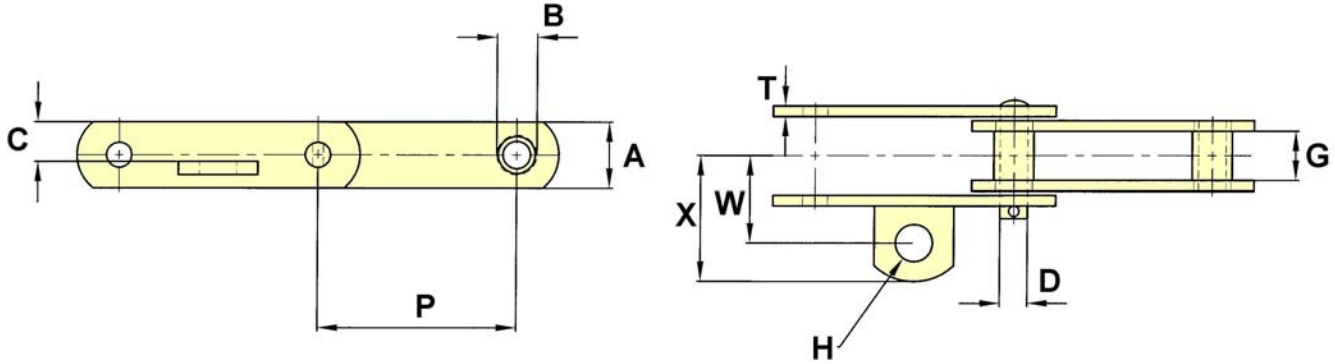

CHAIN NO.	PITCH P	ALLOW. LOAD	U.T.S.	PIN DIA. D	SIDEBAR DEPTH A	MAX. GEARING G	BUSH DIA. B	C	NORMAL SWIVEL PIN DIA. H	T	W	X
B5028	75MM	1,440	20,000	10MM	25MM	18.5MM	15MM	15MM	13.8MM	4MM	32MM	46.5MM
B5039	80MM	2,600	40,000	14MM	35MM	25MM	20MM	20MM	19.8MM	5MM	43MM	59MM

H = NORMAL SWIVEL PIN DIAMETER

Drawing no. 179

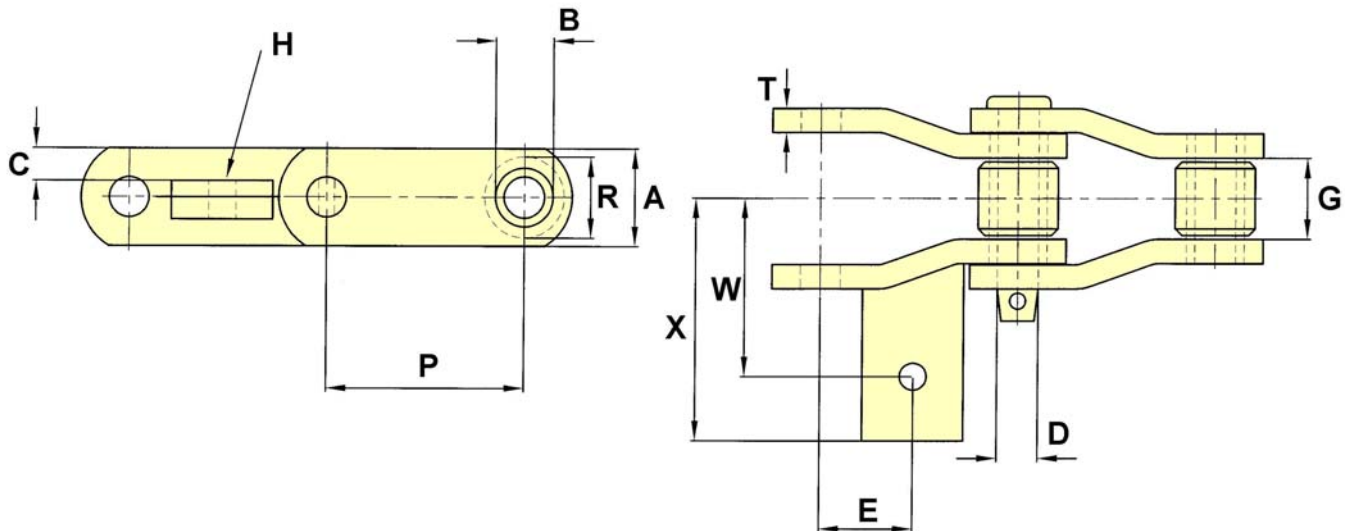

CHAIN NO.	PITCH P	ALLOW. LOAD	U.T.S.	PIN DIA. D	ROLLER DIA. R	SIDEBAR DEPTH A	MAX. GEARING G	BUSH DIA. B	C	E	BOLT DIA. H	T	W	X
B5043	3.075	4,375	60,000	0.62	1.25	1.5	1.25	0.91	0.50	1.45	0.38	0.38	2.75	3.75

Paver / Road Finishing Chains

Welded Lugs

Drawing no. 183

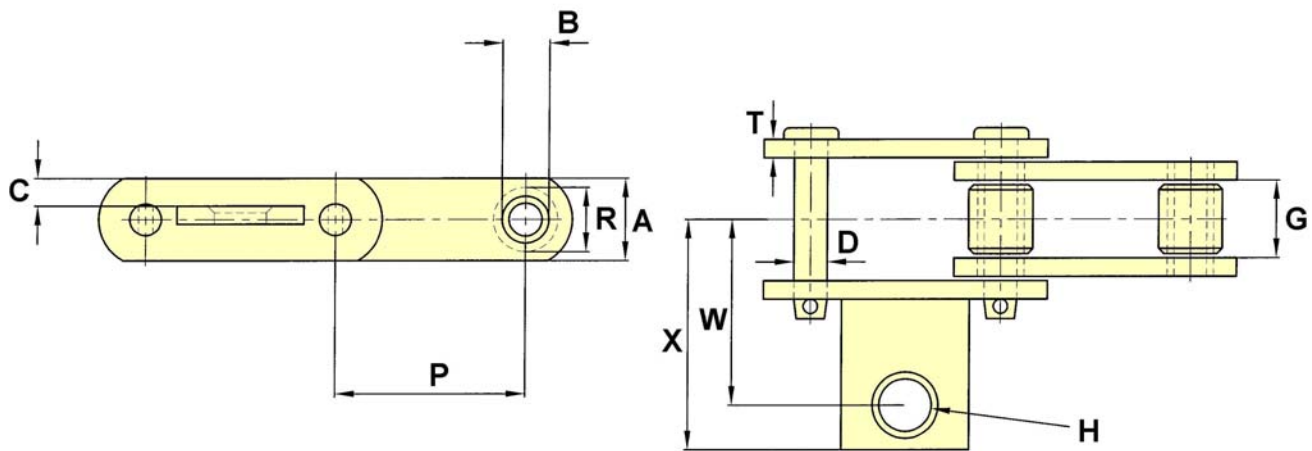

CHAIN NO.	PITCH P	ALLOW. LOAD	U.T.S.	PIN DIA. D	ROLLER DIA. R	SIDEBAR DEPTH A	MAX. GEARING G	BUSH DIA. B	C	SWIVEL PIN DIA. H	T	W	X
B5020	2.609	2,380	23,000	0.43	0.88	1.13	1.06	0.64	0.38	0.69	0.25	2.50	3.11

Paver / Road Finishing Chains

Welded Block Attachments

Drawing no. 175

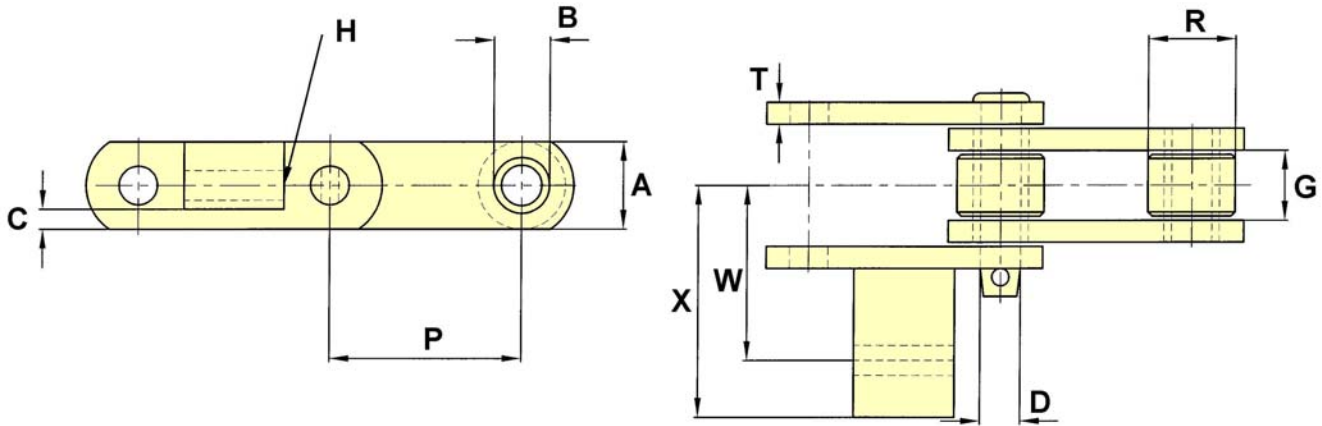

CHAIN NO.	PITCH P	ALLOW. LOAD	U.T.S.	PIN DIA. D	ROLLER DIA. R	SIDEBAR DEPTH A	MAX. GEARING G	BUSH DIA. B	C	BOLT DIA. H	T	W	X
1594	2.75	3,150	30,000	0.56	1.25	1.25	1.00	0.80	0.26	0.38	0.31	2.47	3.13

Drawing no. 180

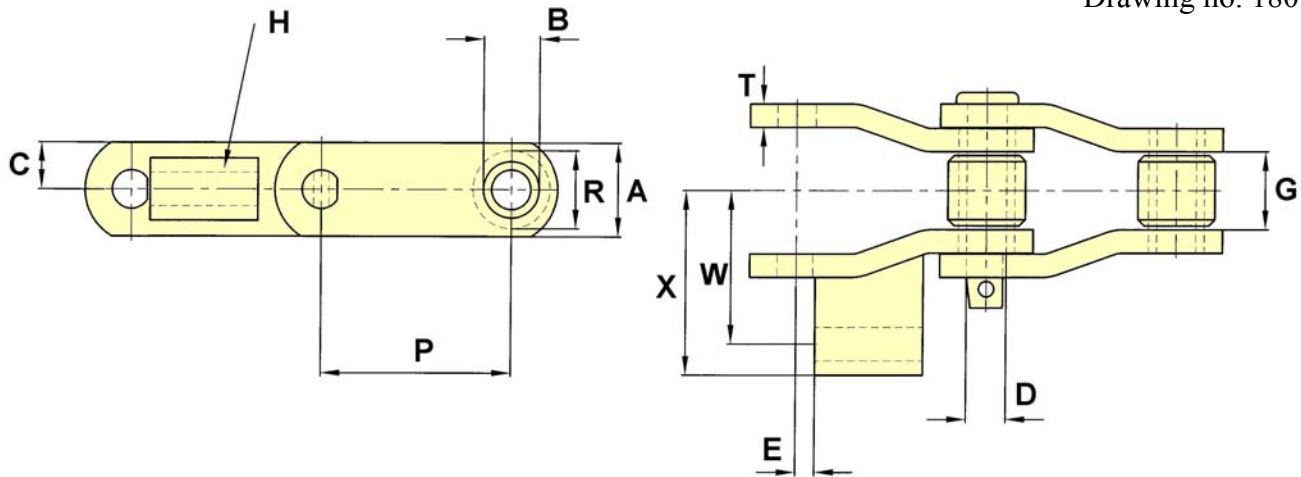

CHAIN NO.	PITCH P	ALLOW. LOAD	U.T.S.	PIN DIA. D	ROLLER DIA. R	SIDEBAR DEPTH A	MAX. GEARING G	BUSH DIA. B	C	BOLT DIA. H	T	W	X
B5046	3.075	4,950	60,000	0.62	1.25	1.5	1.5	0.91	0.75	0.5	0.31	2.47	2.97

Paver / Road Finishing Chains

Welded Block Attachments

Drawing no. 227

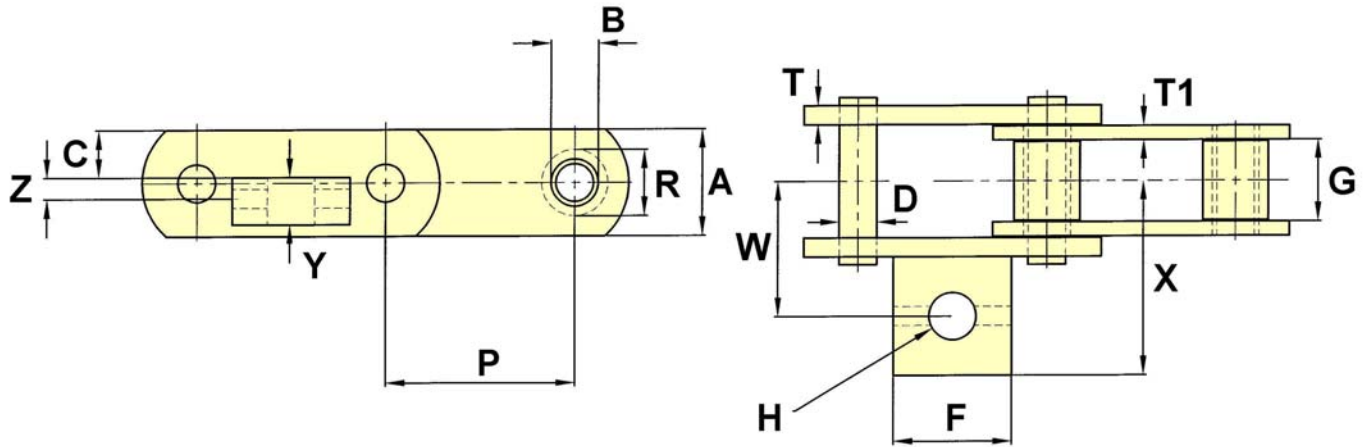

CHAIN NO.	PITCH P	ALLOW. LOAD	U.T.S.	PIN DIA. D	ROLLER DIA. R	SIDEBAR DEPTH A	MAX. GEARING G	BUSH DIA. B
C80 3403	80MM	4,000	33,000	16MM	28MM	45MM	34.5MM	20MM

C	F	HOLE DIA. H	T	T1	W	X	Y	Z
20MM	50MM	20MM	8MM	6MM	57MM	82MM	20MM	9MM

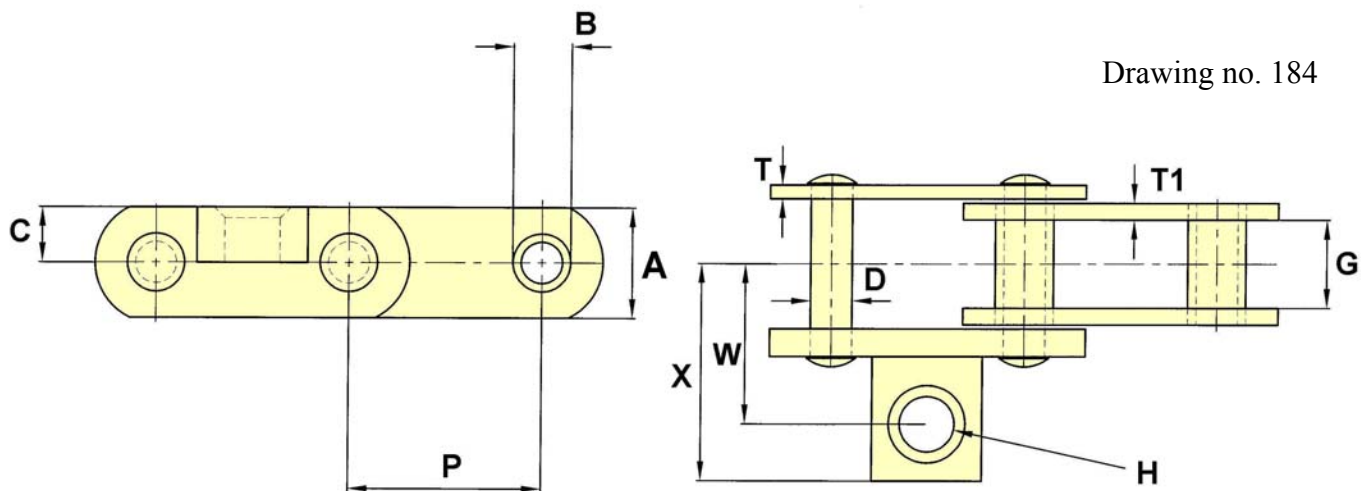

Drawing no. 184

CHAIN NO.	PITCH P	ALLOW. LOAD	U.T.S.	PIN DIA. D	SIDEBAR DEPTH A	MAX. GEARING G	BUSH DIA. B	C	HOLE DIA. H	T	T1	W	X
C70MM	70MM	3,600	31,000	15MM	40MM	32MM	21MM	15MM	20MM	5MM	6MM	60.5MM	78MM

The tabular dimensions and weights are approximate and are not binding.
Design improvements may result in variation from the published figures and verification is recommended.

Paver / Road Finishing Chains

Welded Block Attachments

Drawing no. 259

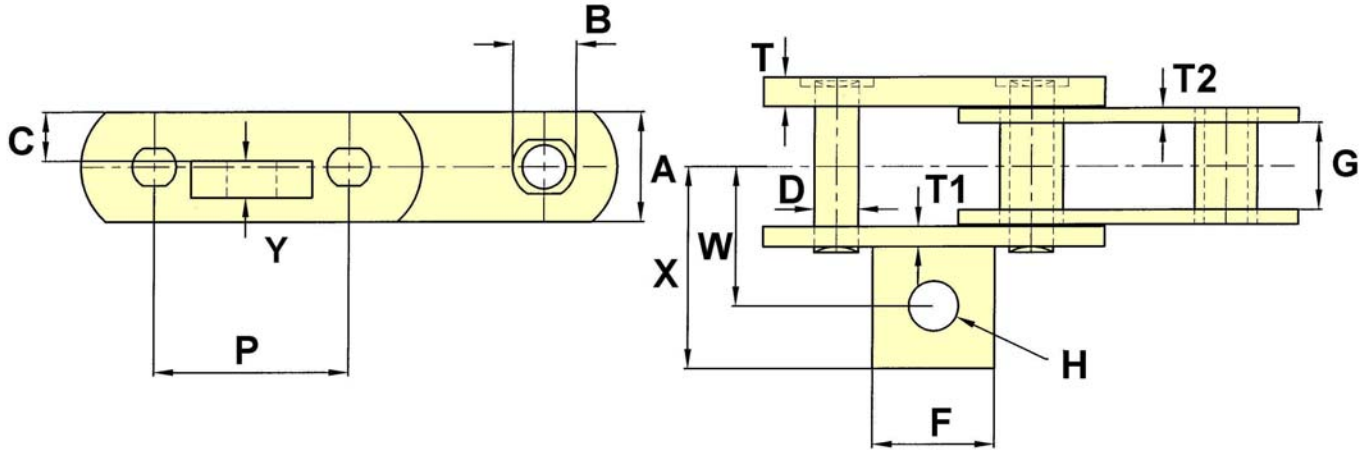

CHAIN NO.	PITCH P	ALLOW. LOAD	U.T.S.	PIN DIA. D	SIDEBAR DEPTH A	MAX. GEARING G	BUSH DIA. B
C80A	3.15	4,600	33,000	18MM	45MM	35MM	26MM

C	F	HOLE DIA. H	T	T1	T2	W	X	Y
20MM	50MM	20.4MM	8MM	12MM	6MM	2.23	3.23	15MM